

Westfalia Separator® EnergyMaster

Technical Data | Easy cost saving
for lube oil treatment systems



Cost saving has become a very attractive proposition on board of ships as the operating costs have risen sharply.

The overall economy and less consumption of fuel are essential to be more competitive and to operate a green and environmentally friendly vessel.

In traditional lube oil treatment systems the energy for heating the lube oil upstream of the centrifugal separator is lost, because after separation the hot oil goes back to the engine sump tank to be cooled by the engine cooling system.

As an integral part of the lube oil treatment system in compact unit design the Westfalia Separator® EnergyMaster recovers part of this energy. The recovery heat exchanger is the heart of this system and designed as a brazed plate heat exchanger.

The Westfalia Separator® EnergyMaster is available as

- An intergrated part of the heater unit, HRU
- A retrofit package for existing heater units

The return of investment period is outstanding short even for retrofit systems.

Technical Data Westfalia Separator® EnergyMaster

Operating principles and constructional features

The cold dirty oil inlet to the separator system is pre-heated by the recovery heat exchanger before the dirty oil is heated up to separating temperature by the standard steam, thermal oil or electric pre-heater. The hot clean oil outlet of the separator is used for pre-heating the cold dirty oil inlet. The footprint is not larger with separator systems in compact unit design. The system contains a brazed plate heat exchanger, a mounting plate, by-pass lines and isolating valves.

The Westfalia Separator® EnergyMaster is easy to handle, self-regulating and maintenance free.

Example heat recovery calculation for a standard design Westfalia Separator® EnergyMaster

Throughput capacity	12,000 l/h
Inlet temperature from separator	90°C
Outlet temperature to sump tank	80°C
Capacity saving	63 kW power or 104 kg/h steam

The Westfalia Separator® EnergyMaster saves the energy on the separator pre-heater system and the same energy is saved on the engine lube oil cooling system.

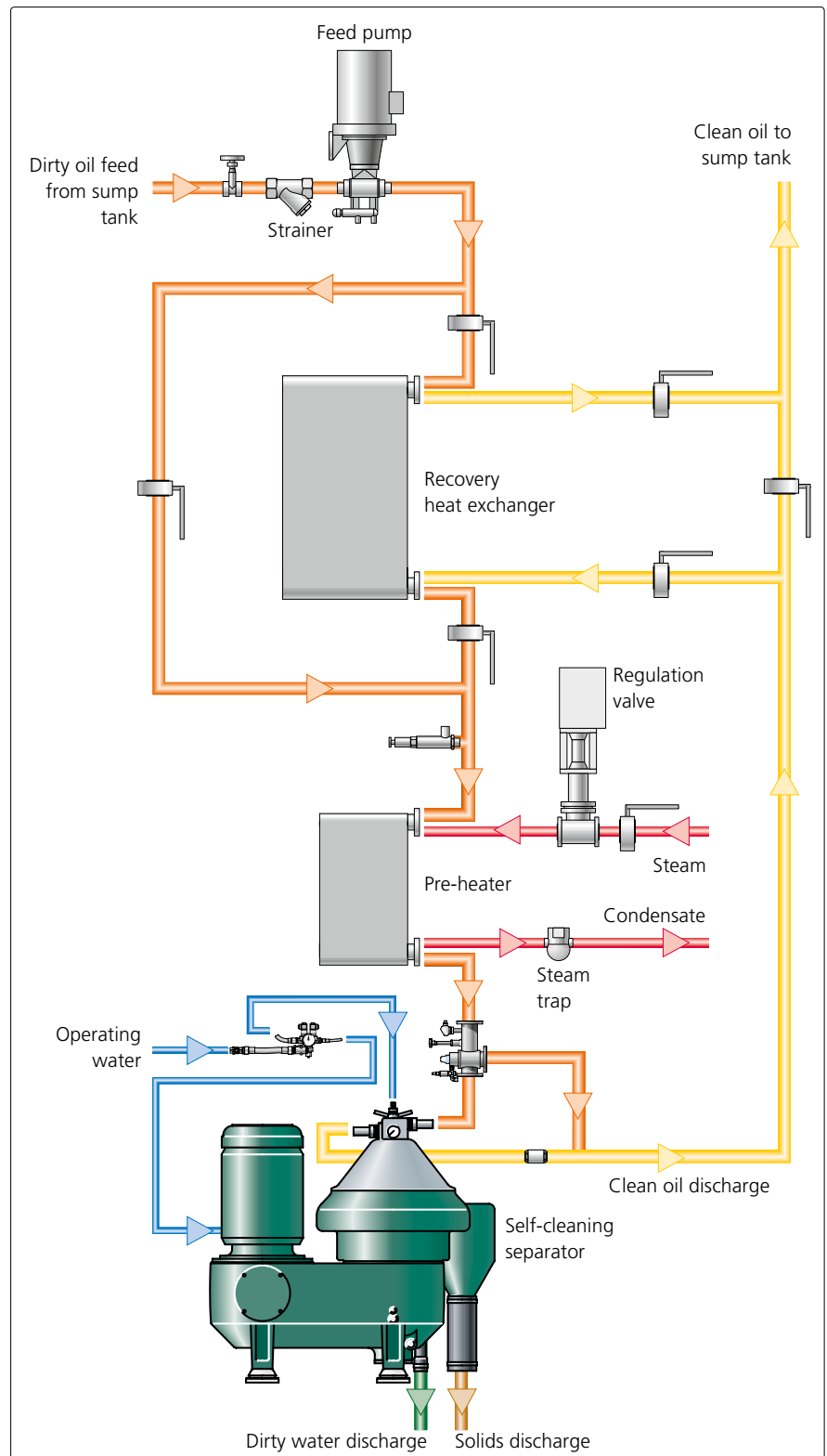

GEA Mechanical Equipment

GEA Westfalia Separator Group GmbH

Werner-Habig-Straße 1 · 59302 Oelde (Germany)

Phone +49 2522 77-0 · Fax +49 2522 77-1778

www.westfalia-separator.com