

Liquids to Value



PROFI[®]
The Future in Beer Filtration

Goodbye Kieselguhr
Welcome **PROFI**[®]

High-performance separators for kieselguhr-free beer filtration



The PROFI® Process

Beer filtration with PROFI®

The PROFI® beer filtration is a combination of high-performance centrifuge and membrane filtration. It enables optimized beer filtration without kieselguhr.

The unfiltered beer containing fine and coarse solids is fed into the rotating bowl and clarified in the disk stack.

The coarse solids slide down into the solids space of the bowl and are continuously discharged. The clarified liquid which still contains fine solids is discharged under gravity or under pressure by a centripetal pump (see above figure, (1)).

This pre-clarified beer is fed into the virtually retentate-free membrane filtration system. Here, the pre-clarified beer with fine solids passes through hollow fibre filter modules. The clarified beer is then transferred to the bottling station (see above figure, (2)). A system for retentate recycling into a tank is not required.

When a certain transmembrane pressure has been reached and the filtration performance starts to deteriorate, the system is emptied by means of CO₂ (see figure, (3)). Cleaning with caustic solution and water then takes place. Following CIP, the modules are disinfected at a temperature of around 80°C (see figure, (4)).

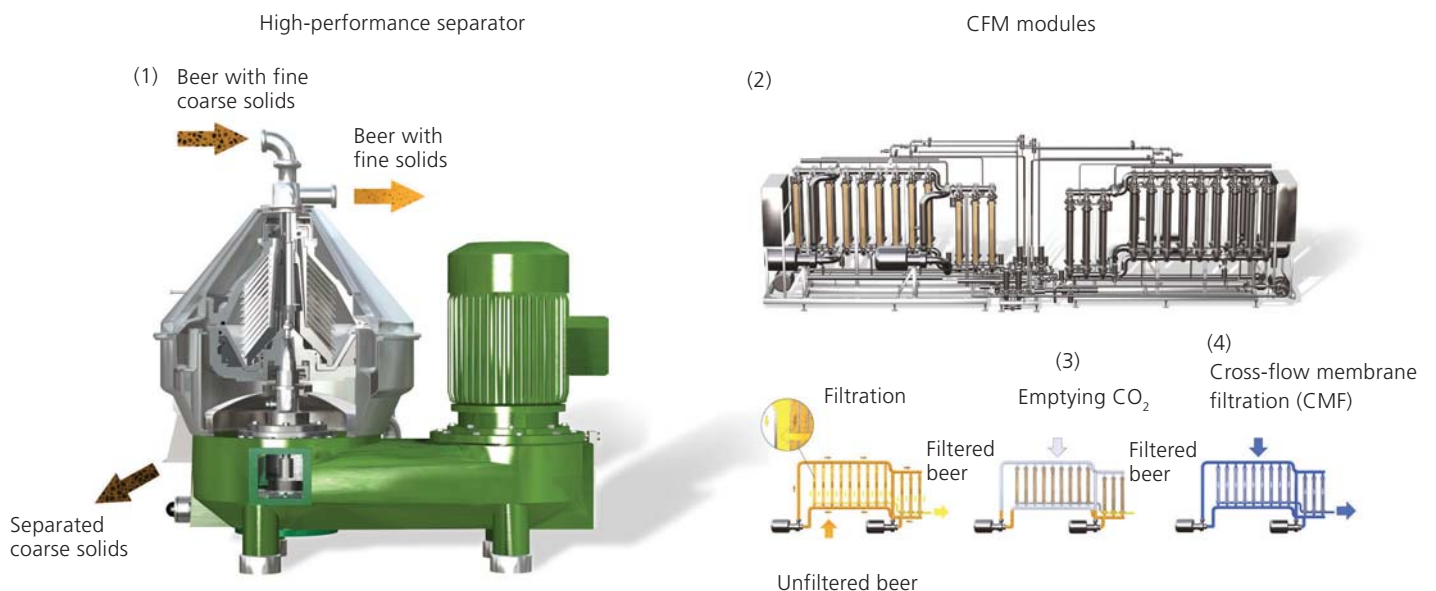
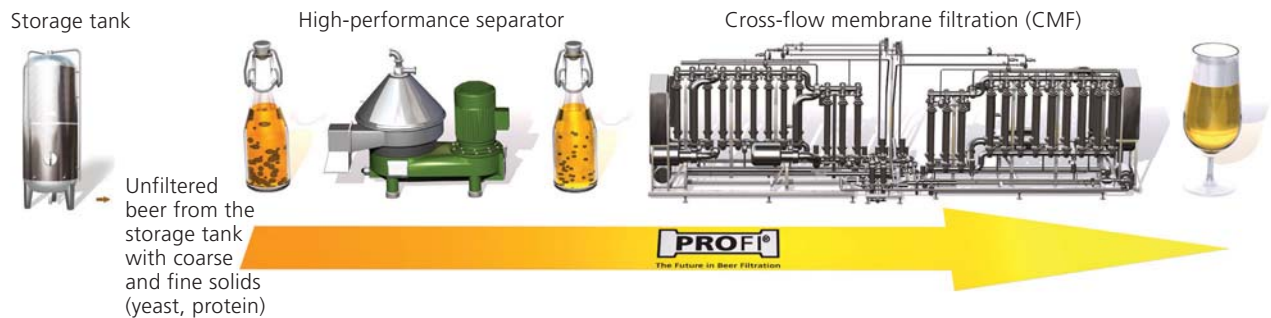

The **PROFI**[®] High-Performance Separator

Design features

Special features of high-performance separators

The centrifuges used in this process differ from standard separators in the following points:

- Patented gentle (hydrohermetic) feed
- High g-force: up to 12,000 g are possible.

Standard separators attain only approx. 7500 g

Advantages of the hydrohermetic feed system

- Low shear forces
- Solids in feed are retained
- Significantly improved clarification
- Viability of the yeast is retained

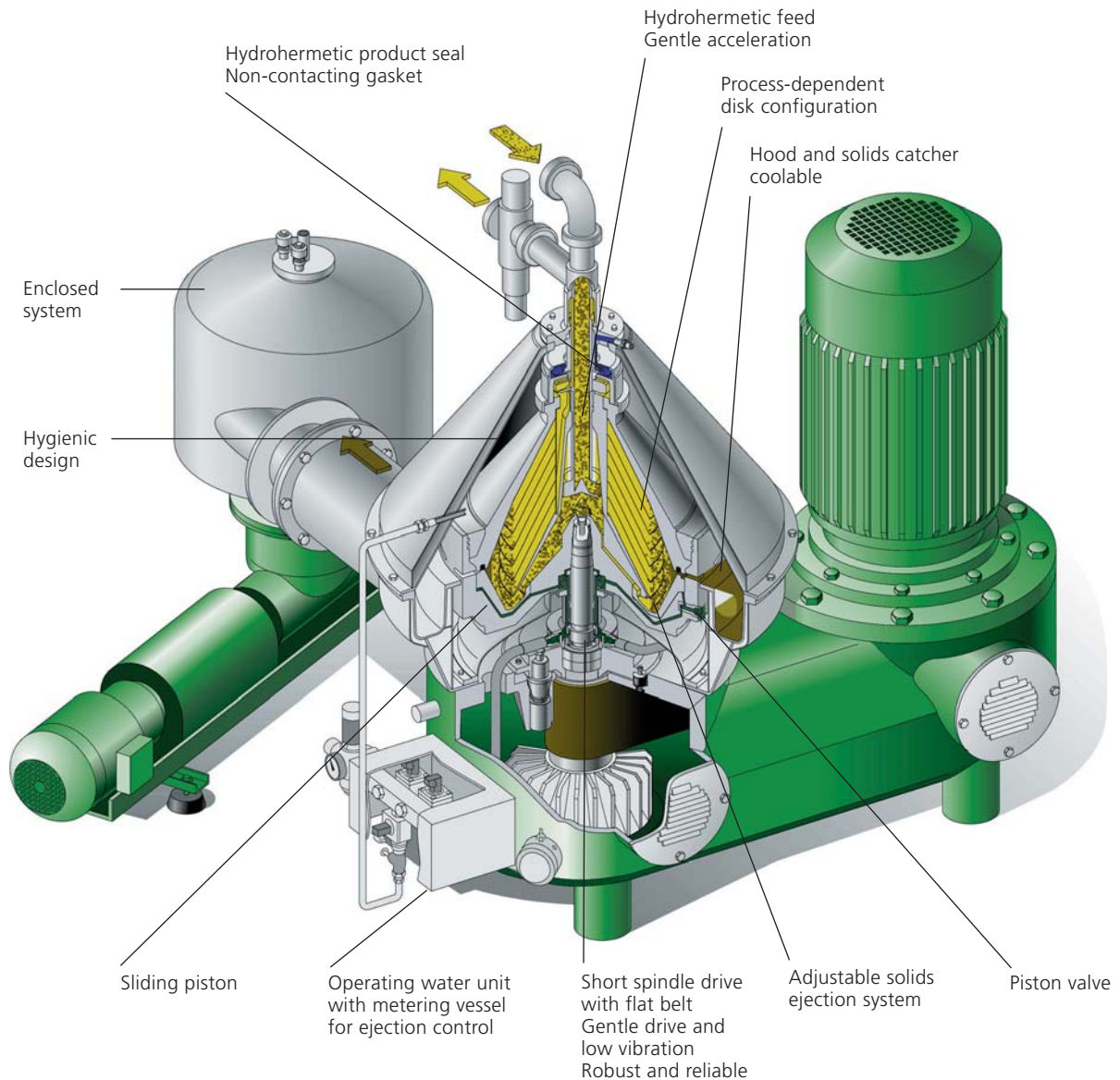

The Customer Benefit

- Very high solids concentration due to a fast ejection system
- This results in low product losses
- The high-performance separators mean that the membrane installations can be rated for smaller flow rates
- Virtually 100 percent of the yeasts are separated by the high-performance separator
- A portion of the proteins is separated by the high-performance separator
- This makes possible virtually retentate-free filtration in the **PROFI®** process
- Viability of the yeast is retained

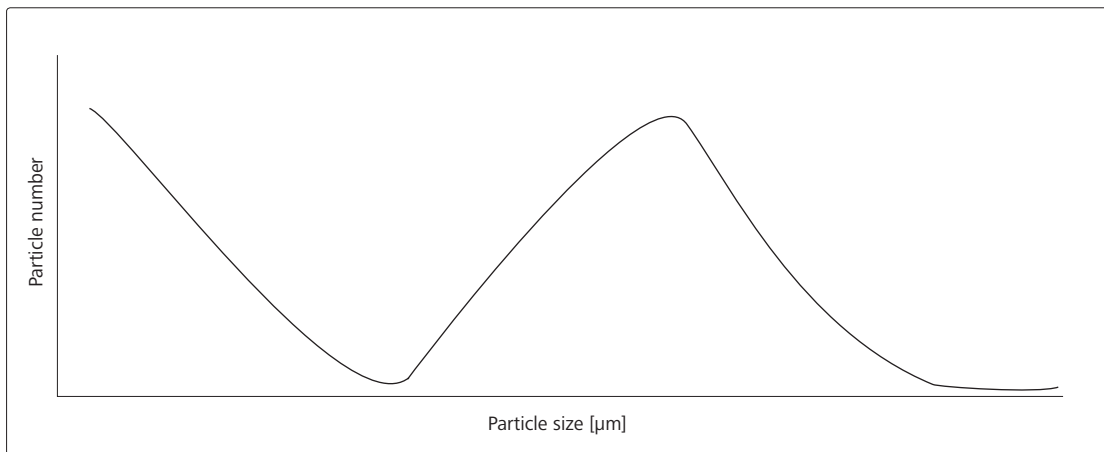

— Particle distribution in the feed before separation

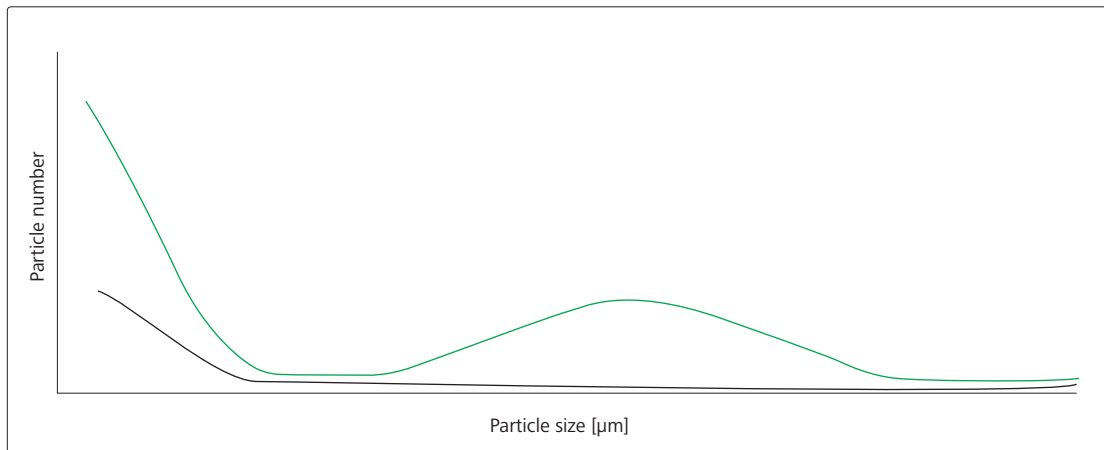

— Particle distribution in the discharge of standard separators
— Particle distribution in the discharge of high-performance separators

PROFI® Separators Overview

High-performance separators	Capacity range for a separation efficiency of at least 99 %
PROFI® 20	up to 20 hl/h
PROFI® 50	up to 50 hl/h
PROFI® 100	up to 100 hl/h
PROFI® 200	up to 200 hl/h
PROFI® 300	up to 300 hl/h
PROFI® 400	up to 400 hl/h



- Beverage Technology
- Dairy Technology
- Renewable Resources
- Chemical/Pharmaceutical Technology
- Marine
- Energy
- Oil & Gas
- Environmental Technology
- Engineering
- Second Hand Machinery
- Original Manufacturer Service

The information contained in this brochure merely serves as a non-binding description of our products and is without guarantee.

Binding information, in particular relating to capacity data and suitability for specific applications, can only be provided within the framework of concrete inquiries.

Westfalia® and Westfalia Separator® are registered trademarks of GEA Mechanical Equipment GmbH.

Printed on chlorine-free bleached paper

B_BE-10-10-0002 EN
Printed in Germany
Subject to modification



GEA Mechanical Equipment

GEA Westfalia Separator Group GmbH

Werner-Habig-Straße 1 · 59302 Oelde (Germany)

Phone +49 2522 77-0 · Fax +49 2522 77-2089

www.westfalia-separator.com