



Technical Data

OTC 2 Mineral Oil Centrifuge

OTC 2-02-137

Operating principles and constructional features

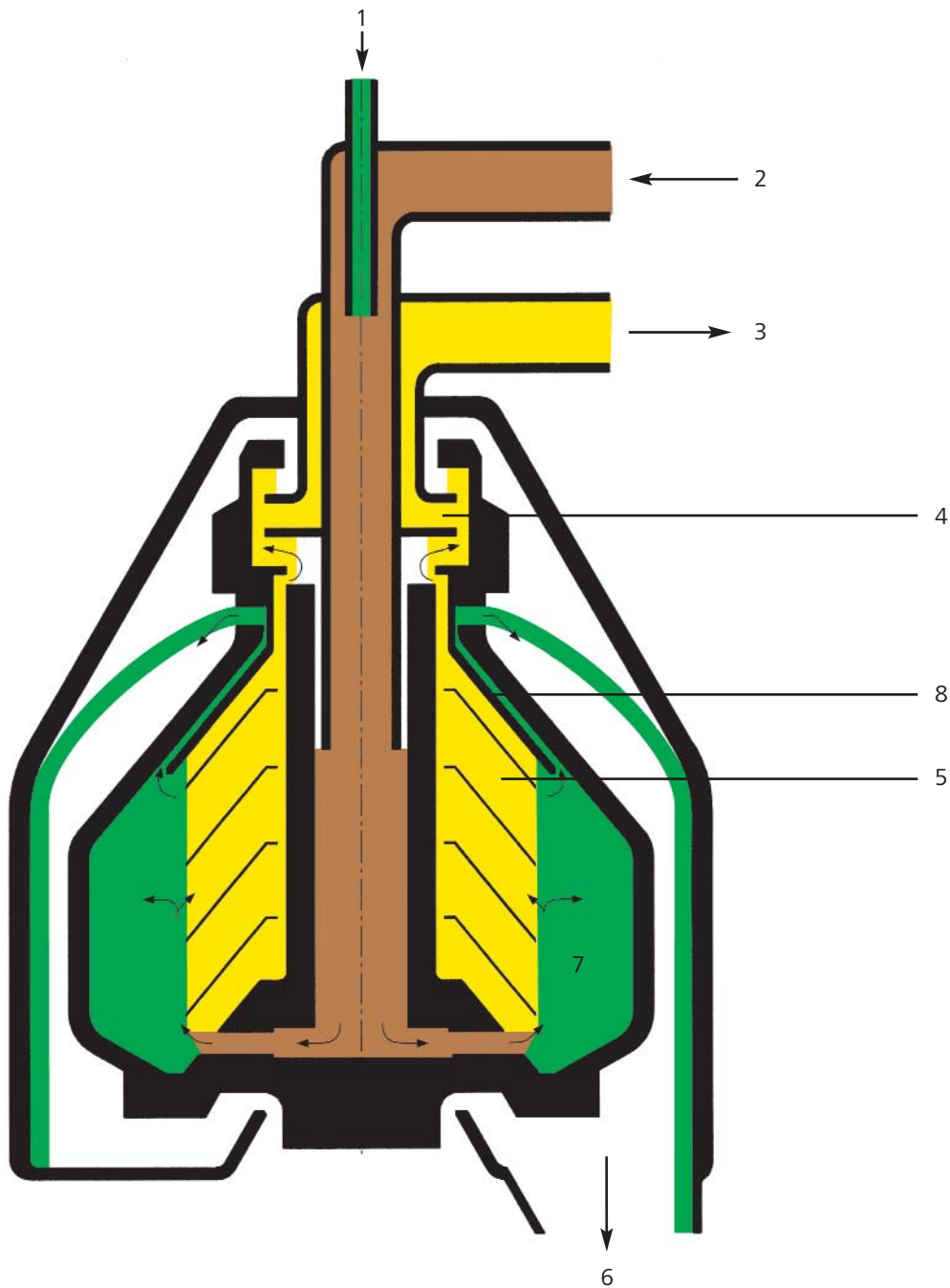

- 1 Make-up water
- 2 Product feed
- 3 Discharge, light liquid phase
- 4 Centripetal pump

- 5 Disc stack
- 6 Discharge, heavy liquid phase
- 7 Solids holding space
- 8 Separating disc

The centrifuge is equipped with a solid-wall bowl. It can be used for either clarification of liquids or separation of liquid mixtures. The product enters the rotating bowl through the product feed (2) and is clarified or separated in the disc stack (5). The separated heavy phase is diverted over the separating disc (8) and discharges freely from the bowl. The clarified light liquid phase is pressure-discharged by the centripetal pump (4). The separated solids collect in the solids holding space (7) and must be removed by hand.

Frame, hood and drive

The separator of enclosed design is equipped with an oil level sight glass. The hood is removable. The machine is driven by a 3-phase AC motor. Power is transferred to the bowl spindle via a flat belt. All bearings are splash-lubricated from a central oil bath.

Materials of construction

Frame:	grey cast-iron GG-25 silumin*
Hood:	silumin
Main bowl parts:	stainless steel
Gaskets:	Buna N

Features

- Standard motor
- Low- noise version
- Light weight
- Bowl of stainless steel
- Light phase discharged under pressure
- Easy conversion into clarifier

Benefits

- Easy installation
- Low maintenance
- Compact unit
- Easy and rapid dismantling of bowl for cleaning
- All product-contacting parts are made of stainless steel

Standard equipment

- 3-phase AC motor
- Rubber cushions
- Motor protection switch
- Set of tools
- Set of commissioning parts
- Technical documentation
- Set of regulating rings
- Set of hoses, 1000 mm long (for feed and discharge)
- Filling water hopper
- Flow detector
- Flow indicator

Additional equipment (at extra cost)

- Set of spare parts 8000 hours
- Set of spare parts 16,000 hours
- Conversion set for clarifier
- Set of bowl inlays (sludge liners)
- For operating voltage 230 V AC, 1 phase
- For operating voltage 110 V AC, 1 phase
- For operating voltage 24 V DC
- Low-weight version (frame of silumin)

* see "additional equipment"

Technical data OTC 2-02-137

Technical data	
Bowl	
Speed	10,000 rpm
Volume	1.2 l
Solids holding space	0.75 l
3-phase AC motor	
Power	1.1 kW
Normal absorbed power	0.6 kW
Speed at 50 Hz	3000 rpm
Speed at 60 Hz	3600 rpm
Design	IM V1
Enclosure	IP 55
Centripetal pump	
Pressure head, HD of the light liquid phase	0.5 bar
Connections	
Feed	R 1/2 in
Discharge heavy phase	R 3/4 in
Discharge light phase	R 1/2 in
Max. separating temperature	100°C/212°F

Weight and shipping data	
Weight	
Separator complete (standard design)	60 kg
(low-weight version)	40 kg
Case dimensions (L x W x H)	640 x 640 x 710 mm
Shipping volume	0.3 m ³
Capacity	
Rated capacity For optimum capacities refer to the table of capacities	1400 l/h

Dimensions in mm



Function

Continuous treatment of fuel and lube oils

Application

Mainly on board of ships and in power stations

Westfalia Separator
Mineraloil Systems GmbH
Werner-Habig-Straße 1
59302 Oelde (Germany)

Phone +49 2522 77-0
Fax +49 2522 77-1778
mineraloilsystems@gea-westfalia.de
www.westfalia-separator.com



Take the Best – Separate the Rest

A company of GEA Group

**Westfalia Separator
Mineraloil Systems**

The information contained in this brochure merely serves as a non-binding description of our products and is without guarantee.

Binding information, in particular relating to capacity data and suitability for specific applications, can only be provided within the framework of concrete inquiries.

9997-0759-000/0206 EN

Printed in Germany

Subject to modification